



Reg. No. :

Name :

SECOND SEMESTER B.TECH. DEGREE EXAMINATION, MAY/JUNE 2016
BE 100 : ENGINEERING MECHANICS

Max. Marks : 100

Duration : 3 Hours

PART – A

Answer **all** the questions. **Each** question carries **5** Marks.**(8×5=40 Marks)**

1. Explain the principle of transmissibility with an example.
2. Three smooth identical spheres A, B and C are placed in a rectangular channel as shown in Fig. 1. Draw the free body diagram of each sphere.

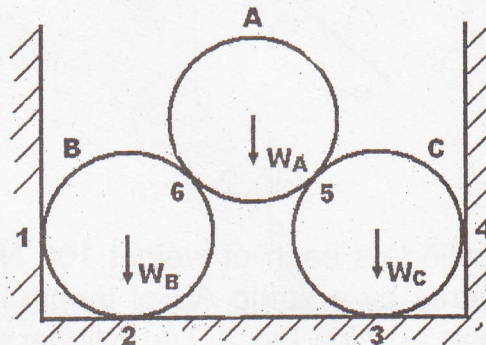

Fig. 1

3. State and prove Parallel axis theorem.
4. Define angle of friction and angle of repose. Prove that angle of repose is equal to angle of friction.
5. A lift carries a weight of 3600 N and is moving with a uniform acceleration of 3.5 m/s^2 . Determine the tension in the supporting cable when the lift is moving upward. ($g = 9.8 \text{ m/s}^2$).
6. What do you mean by instantaneous centre of rotation? How can it be located for a body moving with combined motion of rotation and translation ?



7. Distinguish between Simple Harmonic Motion and Periodic motion.
8. Explain the types of vibrations.

PART – B

Answer **two** questions from **each** set :

SET 1 : Answer **any 2** questions. **Each** question carries **10** Marks. **(2×10=20 Marks)**

9. Determine the magnitude and direction of the resultant of the forces acting on the ring as shown in Fig. 2.

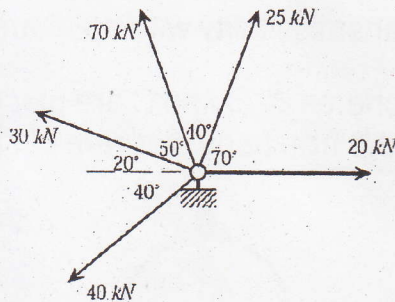

Fig. 2

10. Two smooth circular cylinders each of weight 100 N and radius 15 cm are connected at their centres by a string AB of length 40 cm and rest upon a horizontal plane as shown in below Fig. 3. The cylinder above them has a weight 200 N and radius of 15 cm. Find the force in the string AB and the pressure produced in the floor at the points of contact D and E.

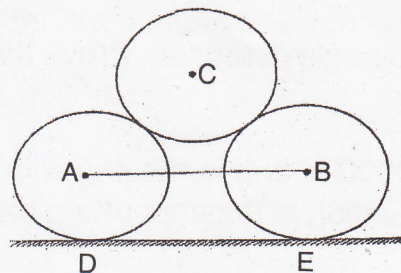

Fig. 3



11. A 5 m bar of negligible weight rests in a horizontal position on the smooth planes as shown in above Fig. 4. Determine the load P and reactions at supports.

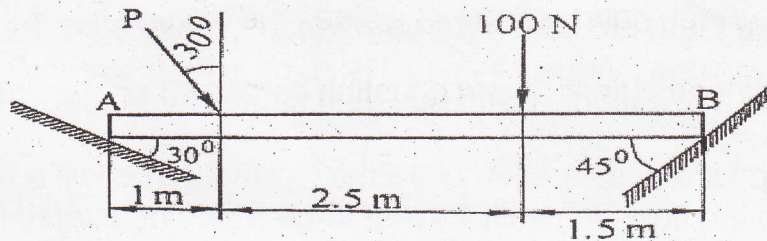
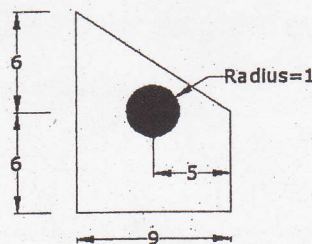

Fig. 4

SET 2 : Answer any 2 questions. Each question carries 10 Marks. (2×10 = 20 Marks)

12. a) Define radius of gyration.
b) Find the Centre of Gravity for the un-shaded composite area shown in Fig.5.



All dimensions in mm

Fig. 5

13. Determine the moments of inertia of the shaded area (Fig. 6) with respect to the x and y axes.

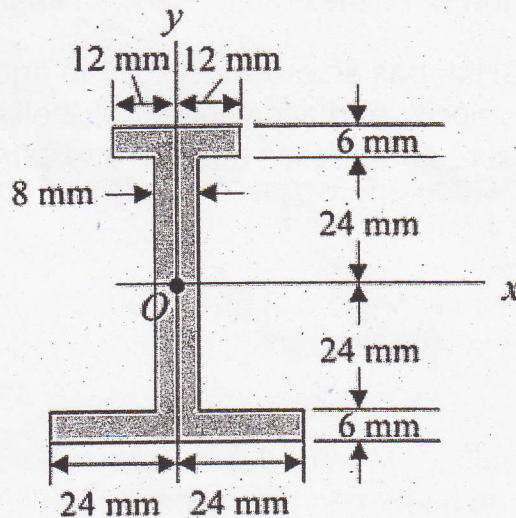

Fig. 6



14. A uniform ladder of 4 m length rests against a vertical wall with which it makes an angle of 45° . The coefficient of friction between ladder and the wall is 0.4 and that between ladder and the floor is 0.5. If a man whose weight is one half that of ladder climbs up then how high will it be when the ladder slips ?

SET 3 : Answer any 2 questions. Each question carries 10 Marks. (2×10=20 Marks)

15. A lift has an upward acceleration of 1.2m/s^2 . What force will a man weighing 750 N exert on the floor of the lift ? What force would he exert if the lift had an acceleration of 1.2 m/s^2 downwards ? What upward acceleration would cause his weight to exert a force of 900 N on the floor ?

16.

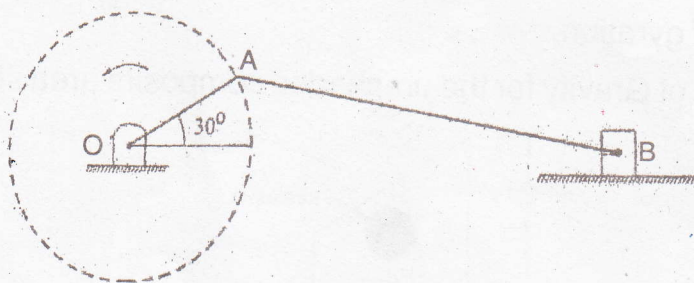

Fig. 7

In the reciprocating engine mechanism shown in Fig. 7, the crank OA rotates at a uniform speed of 300 rpm. The length of the crank and connecting rod are 12 cm and 50 cm respectively. Find the angular velocity of the connecting rod and velocity of the piston when the crank makes an angle of 30° with horizontal.

17. A body moving with SHM, has an amplitude of 1 m and period of oscillation is 2 seconds. Find the velocity and acceleration of the body at $t = 0.4$ second, when the time is measured from mean position and extreme position ?