

Register No.: Name:

SAINTGITS COLLEGE OF ENGINEERING (AUTONOMOUS)

(AFFILIATED TO APJ ABDUL KALAM TECHNOLOGICAL UNIVERSITY, THIRUVANANTHAPURAM)

FIFTH SEMESTER B.TECH DEGREE EXAMINATION (S), FEBRUARY 2023**MECHANICAL ENGINEERING****(2020 SCHEME)****Course Code : 20MET301****Course Name: Mechanics of Machinery****Max. Marks : 100****Duration: 3 Hours****PART A*****(Answer all questions. Each question carries 3 marks)***

1. Define the terms: Mechanism, Machine and Structure
2. Explain Hart mechanism.
3. Define the term pressure angle associated with cam and its importance.
4. How does a tangent cam work?
5. Define the term 'Contact ratio'.
6. Mention the various stages in kinematic synthesis.
7. What do you mean by static equilibrium?
8. Mention the gyroscopic effect of ship on rolling.
9. What is dynamic balancing?
10. Explain primary and secondary unbalance in reciprocating engines.

PART B***(Answer one full question from each module, each question carries 14 marks)*****MODULE I**

11. a) For the kinematic linkages shown in figure, calculate the following. (12)
- (i) Number of binary links (N_b)
 - (ii) Number of ternary links (N_t)
 - (iii) Number of other (quaternary, etc....) links (N_o)
 - (iv) Number of total links (N)
 - (v) Number of loops (L)
 - (vi) Number of joints or Pairs (P_1)
 - (vii) Number of degrees of freedom (F)

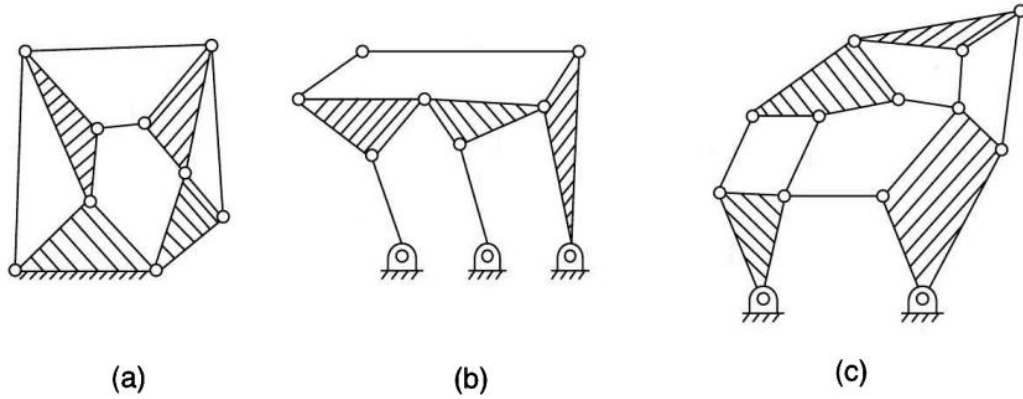

b) State Kennedy’s theorem. (2)

OR

12. In a slider crank mechanism, the crank is 480mm long and rotates at 20 rad/s in the counter-clockwise direction. The length of the connecting rod is 1.6m. The crank turns 60° from the inner-dead centre.

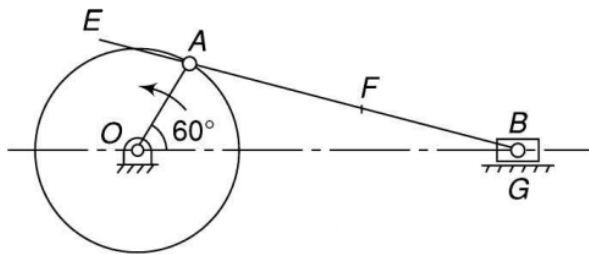

(14)

Determine the following:

- (i) Velocity of the slider
- (ii) Velocity of point “E” located at 450mm on the connecting rod extended from point A

MODULE II

13. What is Corioli’s component of acceleration? Derive the expression for Corioli’s component of acceleration. What are the possible directions? (14)

OR

14. A cam with minimum radius of 25 mm is to be designed for a knife edge follower with the following data:

- To raise the follower through 35 mm during 60° rotation of the cam. (14)
- Dwell for next 40° of the cam rotation
- Descending of the follower during the next 90° of the cam rotation
- Dwell for the rest of the cam rotation.

Draw the profile of the cam if the ascending and descending of the cam is with simple harmonic motion and the line of stroke of the follower is offset 10 mm from the axis of the cam shaft.

MODULE III

15. a) State & Prove Law of gearing (10)
b) The number of teeth of a spur gear is 30 and it rotates at 200 rpm. What will be its circular pitch and the pitch line velocity if it has a module of 2 mm? (4)

OR

16. a) How precision points are obtained using Chebychev spacing? (4)
b) Explain 2-position and 3-position synthesis of a slider crank mechanism by assuming suitable dimensions. (10)

MODULE IV

17. Determine the required input torque on the crank of a slider-crank mechanism for the static equilibrium when the applied piston load is 1500 N. The lengths of the crank and the connecting rod are 40 mm and 100 mm respectively and the crank has turned through 45° from the inner-dead centre. (14)

OR

18. Explain the gyroscopic effect in four wheelers. Derive the condition required for positive reaction of the same. (14)

MODULE V

19. a) Define balancing. (2)
b) Explain the terms static balancing and dynamic balancing in detail with the aid of neat sketches. Also derive expressions for the same. (12)

OR

20. A shaft carries four masses A, B, C and D of magnitude 250kg, 350kg, 480kg and 250kg respectively and revolving at radii 64mm, 60mm, 50mm, and 64mm in planes measured from A at 300mm, 400mm, and 700mm. The angles between the cranks measured anticlockwise are A to B 45°, B to C 70°, C to D 120°. The balancing masses are placed in planes P and Q. The distance between the planes A and P is 100mm, between P and Q is 400mm and between Q and D is 200mm. If the balancing mass Q revolve at a radius of 100 mm, and balance mass P revolve at a radius of 150mm, find their magnitudes and angular positions. (14)
