

Register No.: Name:

SAINTGITS COLLEGE OF ENGINEERING (AUTONOMOUS)

(AFFILIATED TO APJ ABDUL KALAM TECHNOLOGICAL UNIVERSITY, THIRUVANANTHAPURAM)

FIFTH SEMESTER B.TECH DEGREE EXAMINATION (Regular), DECEMBER 2022 ELECTRICAL AND ELECTRONICS ENGINEERING

(2020 SCHEME)

Course Code : 20EET305

Course Name: Signals and Systems

Max. Marks : 100

Duration: 3 Hours

PART A

(Answer all questions. Each question carries 3 marks)

1. Check whether the following signal is linear or nonlinear $y(n)=nx(n)$.
2. Plot $r(-t+2)$, where $r(t)$ is the unit ramp signal.
3. State and prove the time reversal property of continuous time Fourier transform.
4. Determine the response of the system with impulse response $h(t)=u(t)$ for the input $x(t)=e^{-2t}u(t)$.
5. Derive the unit step response of a first order system.
6. Explain Mason's gain formula?
7. An analog signal is expressed by the equation $x(t)= 15\cos 50\pi t+ 15\sin 300\pi t+ 10\sin 100\pi t$. Calculate the Nyquist rate (minimum sampling rate) in Hz for this signal.
8. Find the Z transform and ROC of $x(n) = u(n)-u(n-10)$.
9. Find the Fourier transform of the discrete signal $x(n)=a^n u(n)$.
10. State and prove the time shifting property of discrete time Fourier series.

PART B

(Answer one full question from each module, each question carries 14 marks)

MODULE I

11. a) Classify the following signals into energy, power, or neither. (8)
Determine Energy and Power
i) $(e^{-3t}) u(t)$ ii) $(1/3)^n u(n)$
- b) Explain various types of non-linear systems. (6)

OR

12. a) Find whether the system $y(t) = at^2 x(t) + bt x(t-2)$ is (10)
 a) linear b) static c) time invariant d) causal
 b) Explain the properties of discrete convolution. (4)

MODULE II

13. a) Determine the initial and final values for the given Laplace transform. (4)

$$X(S) = \frac{s + 5}{s^2 + 3s + 2}$$

- b) Find the Fourier transform of the following function. (5)
 $x(t) = \cos \omega_0 t u(t)$
 c) Find the Fourier transform of the following function (5)
 $x(t) = \sin(\pi t) e^{-2t} u(t)$.

OR

14. a) Obtain the trigonometric Fourier series coefficient of the periodic function shown below. (10)

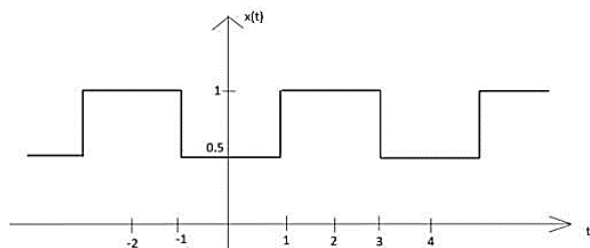

- b) With the help of a circuit diagram explain Force – Voltage and Force – Current analogy? (4)

MODULE III

15. a) Obtain the overall transfer function using block reduction techniques. (8)

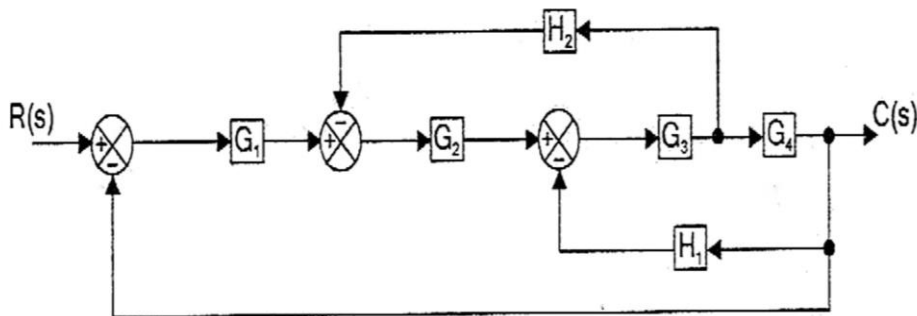

- b) Analyze the stability of the given LTI system, whose characteristic equation is given by $Q(s) = s^5 + s^4 + 2s^3 + 2s^2 + 3s + 5$ using Routh's stability criterion. (6)

OR

16. a) For the signal flow graph shown below, determine the transfer function. (10)

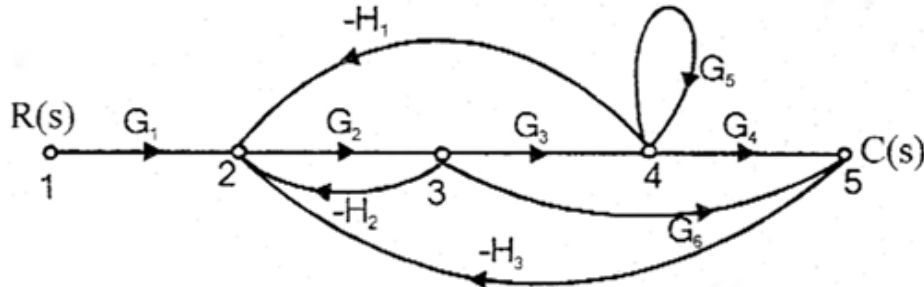

- b) State the necessary and sufficient conditions to be satisfied for stability of an LTI system. Prove that the necessary condition only has to be satisfied for first and second order systems. (4)

MODULE IV

17. a) Obtain the time domain signal corresponding to the following z transform. (6)

$$X(z) = \frac{2z-7}{(z-3)(z-2)} \quad \text{with ROC } |z| < 2$$

- b) Solve difference equation using z -transform $y(n) + 2y(n-1) = x(n)$ with $x(n) = \left(\frac{1}{3}\right)^n u(n)$ and the initial conditions $y(-1) = 1$. (8)

OR

18. a) Find the inverse z -transform of (10)

$$x(z) = \frac{3z^{-1}}{(1-z^{-1})(1-2z^{-1})}$$

if ROC i) $|Z| > 2$ ii) $|Z| < 1$ iii) $1 < |Z| < 2$

- b) What is pulse transfer function? Derive the transfer function of a ZOH circuit. (4)

MODULE V

19. a) Check the stability of the sampled data control system with the following characteristic equation using Jury's stability test $z^4 + 0.6z^3 + 0.63z^2 - 0.37z + 0.065 = 0$. (8)

- b) Find the Discrete Fourier series representation of $x[n] = \cos \frac{2\pi}{8}n$. (6)

OR

20. a) Find the magnitude and phase response of the causal system (8)
$$y(n) - y(n-1) + \frac{3}{16}y(n-2) = x(n) - 0.5x(n-1).$$
- b) Determine the direct form II realization for the following system (6)
$$y(n) = -0.1y(n-1) + 0.72y(n-2) + 0.7x(n) - 0.252x(n-2).$$
