

Register No.: Name:

SAINTGITS COLLEGE OF ENGINEERING (AUTONOMOUS)

(AFFILIATED TO APJ ABDUL KALAM TECHNOLOGICAL UNIVERSITY, THIRUVANANTHAPURAM)

FIRST SEMESTER B.TECH DEGREE EXAMINATION (Regular), DECEMBER 2022

(2020 SCHEME)

Course Code : 20EST100

Course Name: Engineering Mechanics

Max. Marks : 100

Duration: 3 Hours

PART A

(Answer all questions. Each question carries 3 marks)

1. List out and explain systems of forces.
2. State and prove Varignon's theorem of moments.
3. A block weighing 1500 N, overlying a 10° wedge on a horizontal floor and leaning against a vertical wall, is to be raised by applying a horizontal force to the wedge. Assuming the coefficient of friction between all the surfaces in contact to be 0.3. Draw the free body diagram of the wedge and the block.
4. Define coefficient of friction. Show that the coefficient of friction is tangent of the angle of friction.
5. State and explain parallel axis theorem.
6. Discuss the generation of area by theorem of Pappus Guldinus
7. The equations of motion of a particle moving in a straight line is given by $S = 20t + 5t^2 - 3t^3$ where S is in metres and t in seconds. Find the velocity and acceleration at the start.
8. Discuss the use of D'Alembert's principle used for the analysis of a moving rigid body.
9. What do you mean by general plane motion? Give two examples of bodies performing combined motion of rotation and translation.
10. Distinguish between simple harmonic motion and periodic motion.

PART B

(Answer one full question from each module, each question carries 14 marks)

MODULE I

11. a) Four forces are acting on a bolt as shown in figure. Determine the magnitude and direction of the resultant force. (7)

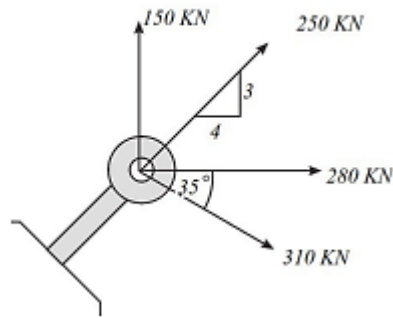

- b) For the system of forces, determine the magnitude, direction and position of the resultant force about A. (7)

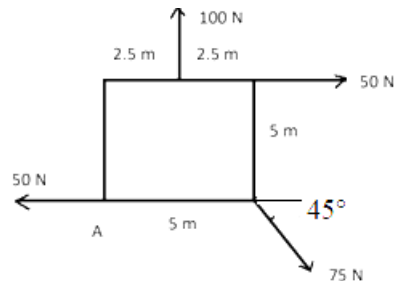

OR

12. Two smooth circular cylinders each of weight 50N and radius 20 cm are connected at their centres by a string AB of length 40 cm and rest upon a horizontal plane as shown in figure. The cylinder above them has a weight of 100N and radius of 20 cm. Find the force in the string AB and pressure produced in the floor at the points of contact D and E. (14)

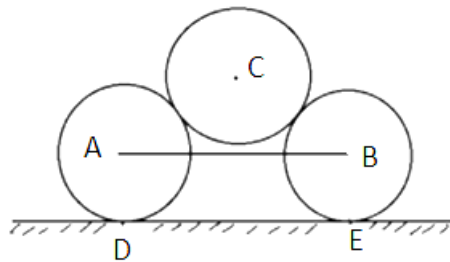

MODULE II

13. a) A uniform ladder AB of length 4m and weighing 300N is placed against a smooth wall with its lower end 1.5m from the wall. The coefficient of friction between the ladder and the floor is 0.25. What is the frictional force acting at the point of contact between the ladder and the floor? Show that the ladder will remain in equilibrium in this position. (7)

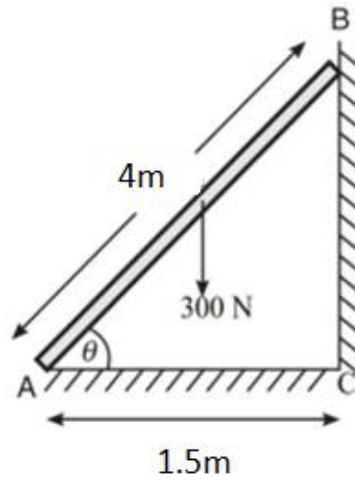

- b) Explain angle of friction and angle of repose. Show that angle of repose is equal to angle of friction. (7)

OR

14. A body, resting on a rough horizontal plane, required a pull of 150N inclined at 30° to the plane just to move it. It was found that a push of 200N inclined at 30° to the plane just moved the body. Determine the weight of the body and the coefficient of friction. (14)

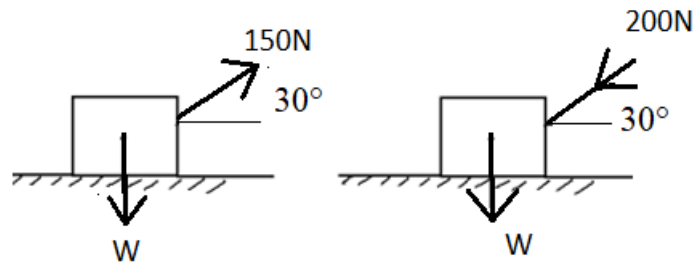

MODULE III

15. Find the centroid of the cross-sectional area of a Z section shown in figure.

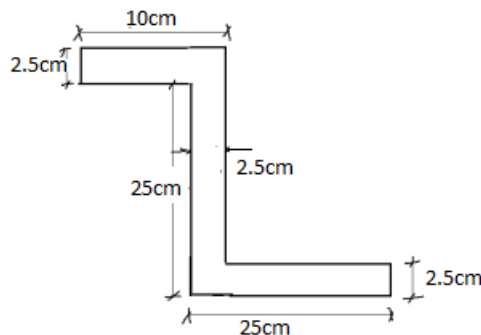

(14)

OR

16. Find the resultant of the force system shown in Fig. in which $P = 280\text{N}$, $Q = 260\text{N}$ and $R = 210\text{N}$. (14)

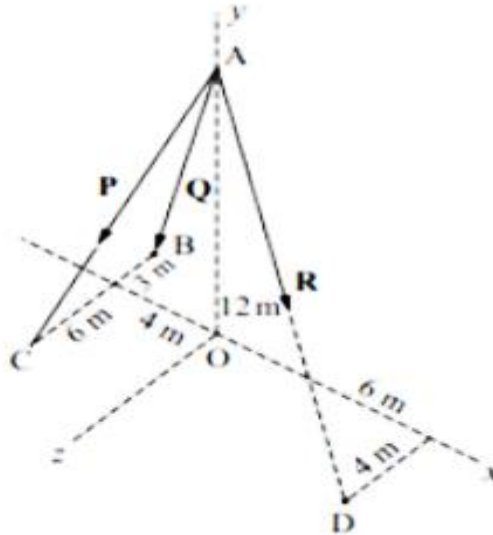

MODULE IV

17. An aeroplane is flying at a height of 200m with horizontal velocity of 70m/s. A shot is fired from a gun from the ground when aeroplane is exactly above the gun. What should be the minimum initial velocity of the shot and angle of elevation in order to hit the aeroplane. (14)

OR

18. A lift has an upward acceleration of 1.2m/s^2 . What force will a man weighing 750N exert on the floor of the lift? What force would he exert if the lift had an acceleration of 1.2m/s^2 downwards? What upward acceleration would cause his weight to exert a force of 900N on the floor. (14)

MODULE V

19. a) A particle moving with simple harmonic motion has velocities of 8m/s and 4m/s when at the distance of 1m and 2m from the mean position. Determine (i) amplitude, (ii) period, (iii) maximum velocity, and (iv) maximum acceleration of the particle. (10)
- b) A flywheel of mass 5tonne starts from rest and gets up a speed of 150rpm in 3minutes. Find the average torque exerted on it if the radius of gyration of wheel is 50cm. (4)

OR

20. A flywheel is made of steel ring 30mm thick & 300mm wide plate with mean diameter of 1.5m. If initially the flywheel is rotating at 250rpm, find the time taken by the wheel in coming to rest due to frictional couple of 150Nm. Take mass density of steel as 7900kg/m^3 . Neglect the effect of spokes. (14)
