

G 1286

(Pages : 4)

Reg. No.....

Name.....



**B.TECH. DEGREE EXAMINATION, MAY 2015**

**First and Second Semester**

EN 010 104—ENGINEERING MECHANICS

(Common for all Branches)

{Regular/Improvement/Supplementary}

[New Scheme—2010 Admission onwards]

Time : Three Hours

Maximum : 100 Marks

**Part A**

*Answer all questions.*

*Each question carries 3 marks.*

1. State principle of transmissibility.
2. Define the terms Polar moment of Inertia and radius of gyration.
3. State the assumptions made in the analysis of trusses.
4. Explain the terms "Kinematics" and "Kinetics".
5. Explain the conservation of law of linear momentum.

(5 × 3 = 15 marks)

**Part B**

*Answer all questions.*

*Each question carries 5 marks.*

6. Represent a Force 100 N passing through the points (2, 3, 4) and (7, 6, 9) in vector form and find its moment about (4, 5, 6).
7. State the theorem of Pappus-Guldinus of finding volume and explain with an example.
8. State the Coloumb's Laws of Friction.
9. State the Equation of motion for translation.
10. Explain the following :—
  - (a) D'Alembert's Principle.
  - (b) Moment of momentum.

(5 × 5 = 25 marks)

Turn over

Part C

Answer all questions.

Each question carries 12 marks.

11. A roller of 600 mm. diameter and 2500 N weight is to be pulled over an obstacle of height of 150 mm. by a horizontal pull  $F$  applied at the top end point of the wheel. Find the minimum magnitude of  $F$  required to overturn the wheel over the obstacle.

Or

12. Two identical rollers, each of weight  $Q = 450\text{ N}$  are supported by an inclined plane and a vertical wall as shown in Fig. 1. Assuming smooth surfaces find the reactions induced at the points of support A, B and C.

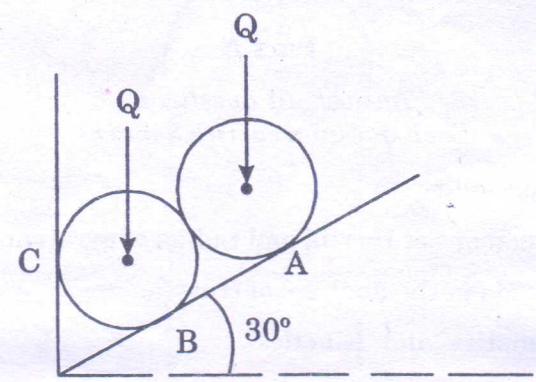

Fig. 1

13. A uniform ladder of 250 N weight rests on the smooth vertical wall and rough horizontal ground making an angle  $45^\circ$  with the horizontal ground. Find the Frictional Force of the ground using principle of virtual work.

Or

14. Determine the moment of inertia of the section shown in Fig. 2. about AB as well as about its centroid axis parallel to AB.

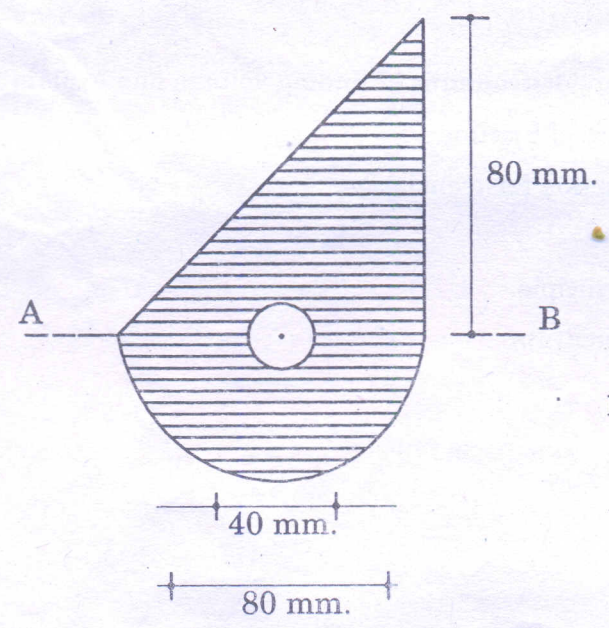

Fig. 2

15. Determine the Force in each member of truss as shown in Fig. 3. The triangle ACB is isosceles with  $30^\circ$  angle at A and B and  $P = 5 \text{ kN}$ .

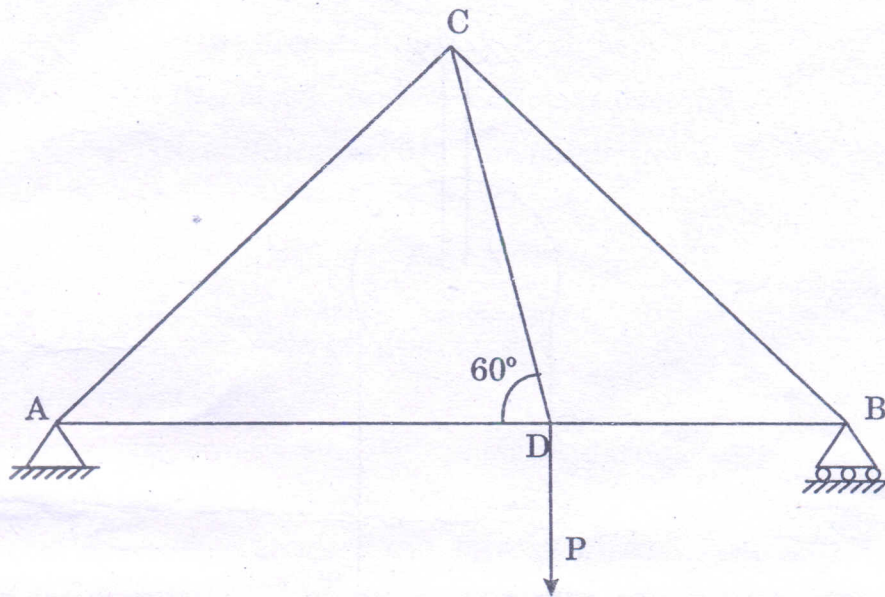

Fig. 3

Or

16. A body resting on a rough horizontal plane required a pull of  $18 \text{ kN}$  at  $30^\circ$  to the horizontal. Just to move the body. It was also Found a push of  $22 \text{ kN}$  at  $30^\circ$  to the horizontal is also sufficient just to move the body. Find the weight of the body and coefficient of friction.
17. A particle is dropped from the top of a tower  $80 \text{ m}$ . high. Another particle is projected upwards from the base of the tower and meets the first particle at a height of  $20 \text{ m}$ . from the base. Find the velocity with which the second particle is projected upwards.

Or

18. An aeroplane is flying horizontally with velocity of  $150 \text{ m./sec.}$ , releases a bomb at a height of  $600 \text{ m}$ . Determine the time taken by the bomb to reach the ground and also determine the magnitude and direction and the velocity with which it will strike the ground.

Turn over

19. Two blocks A and B of weight 80 N and 60 N are connected by a string and passes over a frictionless pulley as shown in Fig. 4. Determine the acceleration of blocks A and B and the tension in the string.

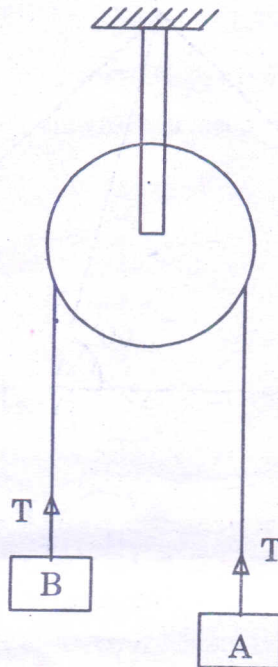

Fig. 4

Or

20. A train of 5,000 kN weight is moving up a plane whose gradient is 1 in 100. When the train is moving with a speed of 20 km/hr, the acceleration is  $0.2 \text{ m/s}^2$ . Frictional resistance is 5 N per kN weight of the train. Determine the power developed by the engine.

(5 × 12 = 60 marks)

