

Register
No.:

..... Name:

SAINTGITS
 LEARN.GROW.EXCEL

**SAINTGITS COLLEGE OF ENGINEERING
 KOTTAYAM, KERALA**

 (AN AUTONOMOUS COLLEGE AFFILIATED TO
 APJ ABDUL KALAM TECHNOLOGICAL UNIVERSITY, THIRUVANANTHAPURAM)

FIRST SEMESTER B.TECH DEGREE EXAMINATION(S), MAY 2022
Course**20EST110****Code:****Course****ENGINEERING GRAPHICS****Name:****Max.****100****Marks:****Duration: 3 Hours**

Instructions: Retain Construction lines. Show necessary dimensions. Answer any ONE question from each module. Each question carries 20 marks

MODULE I

1. A line AB has its point A in HP and 30 mm in front of VP. Point B in VP and 60 mm above HP. The distance between end projectors are 70 mm. Draw the projections and find true length of line and inclinations with HP and VP. Also locate the traces (20)

OR

2. A line PQ of 90 mm long is inclined at 30° to HP. Its end P is 12 mm above HP and 20 mm in front of VP. Its front view measures 65 mm. Draw the projections and determine its inclination with VP. Also locate the traces (20)

MODULE II

3. A pentagonal pyramid of base 25 mm and height 60 mm rest on a corner of its base in such a way that the slant edge containing that corner makes an angle of 45° with HP and 30° with VP (20)

OR

4. A triangular prism of base side 30 mm and length 50 mm has a base edge on HP, axis inclined at 35° to HP. The base edge on which it rests is inclined 45° to VP. Draw the projections of solid (20)

MODULE III

5. A cone of base diameter 50 mm and axis 65 mm is resting upon its base on HP. It is cut by a vertical plane which makes an angle of 45° with VP and is 10 mm away from the axis. Draw the sectional front view showing the section and true shape of the section (20)

OR

6. An ant starts from a point on the circumference of the bottom base of a cylindrical jar, base diameter 50 mm and height 60 mm and moves around it and reach a point on the top circular end face vertically above the starting point. Show the shortest path of the ant in the front view of the cylinder (20)

MODULE IV

7. The frustum of a cone has base diameter 50 mm, top diameter 40 mm and height 60 mm. It is placed centrally on the top of a rectangular slab of size 80 mm x 60 mm and thickness 20 mm. Draw the isometric view of the combination (20)

OR

8. A sphere with 60 mm diameter is surmounted centrally on the top of a square block with 70 mm side and 20 mm height. Draw the isometric projection of the combination of solids (20)

MODULE V

9. A square prism of base side 35 mm and axis length 65 mm is resting on one of its rectangular faces on GP. The base nearer to PP is parallel to it and 15 mm behind it. The station point is 50 mm to the left of the axis of the prism, 55 mm above the ground plane and 30 mm in front of the picture plane. Draw the perspective view of the prism (20)

OR

10. Draw three orthographic views with dimensions of the object shown in figure below
 i) Top view
 ii) Frond view
 iii) Left hand side view

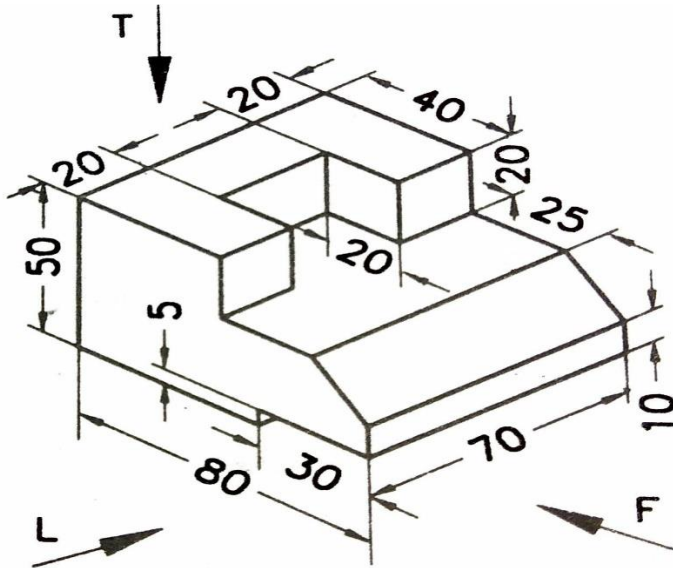

(20)
