

Register No: Name:



SAINTGITS COLLEGE OF ENGINEERING KOTTAYAM, KERALA

(AN AUTONOMOUS COLLEGE AFFILIATED TO
APJ ABDUL KALAM TECHNOLOGICAL UNIVERSITY, THIRUVANANTHAPURAM)

FIRST SEMESTER M.TECH. DEGREE EXAMINATION(R), MARCH 2021 (MACHINE DESIGN)

Course Code: 20MEMDT107

Course Name: DESIGN OF POWER TRANSMISSION ELEMENTS

Max. Marks: 60

Duration: 3 Hours

Use of design data book is permitted

PART A

(Answer all questions. Each question carries 3 marks)

1. What are the advantages of Flat Belt Drive?
2. What are the applications of a Chain Drive?
3. Differentiate between open and crossed types of ray diagrams.
4. Write notes on Lubrication of roller Chains.
5. What are the thermal considerations to be considered in brake design?
6. Briefly describe a Band Brake.
7. Differentiate between single disc clutch and multiple disc clutch.
8. Write short notes on Cone clutch.

PART B

(Answer one full question from each module, each question carries 6 marks)

MODULE I

9. Derive a relation for Centrifugal Tension in the Belt. (6)

OR

10. Design a belt drive to transmit 150 HP for a system consisting of 2 pulleys of diameter 90 cm and 120 cm. Centre distance of 360 cm, belt speed 20 m/s. Coefficient of friction 0.3, slip of 1.2 % at each pulley and 5 % friction loss at each shaft and 20 % overload. (6)

MODULE II

11. Briefly describe the Design Procedure for Chain Drive. (6)

OR

12. With the help of a neat sketch, explain chordal action in chain. (6)

241A1

MODULE III

13. Design a 4-speed gear box for a machine. The speed should vary approximately from 200 to 450 rpm. The input shaft speed for a machine is 600 rpm. (6)

OR

14. Design a nine-speed gear box for a grinding machine with a minimum speed of 100 rpm and a maximum speed of 700 rpm. The motor speed is 1400 rpm. Determine the speed at which the input shaft is to be driven. (6)

MODULE IV

15. What are the factors for selection of a lubricant? (6)

OR

16. Write short notes on the working principle of Servo Motor. (6)

MODULE V

17. A differential band brake is shown below. The width and the thickness of the steel band are 100 mm and 3 mm respectively and the maximum tensile stress in the band is 50 N/mm^2 . The coefficient of friction between the friction lining and the brake drum is 0.25. Calculate: (6)

- (i) the tensions in the band;
 - (ii) the actuating force; and
 - (iii) the torque capacity of the brake.
- Find out whether the brake is self-locking.

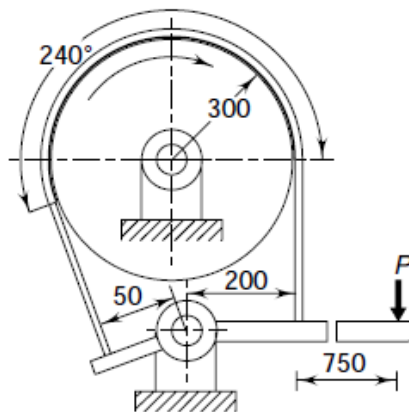

OR

18. A single block brake with a torque capacity of 250 N-m is shown below. The brake drum rotates at 100 rpm and the coefficient of friction is 0.35. Calculate (6)

- (i) the actuating force and the hinge-pin reaction for clockwise rotation of the drum;
 - (ii) the actuating force and hinge-pin reaction for anticlockwise rotation of the drum;
 - (iii) the rate of heat generated during the braking action; and
 - (iv) the dimensions of the block, if the intensity of pressure between the block and brake drum is 1 N/mm^2 . The length of the block is twice its width.
- State whether the brake is self-locking.

241A1

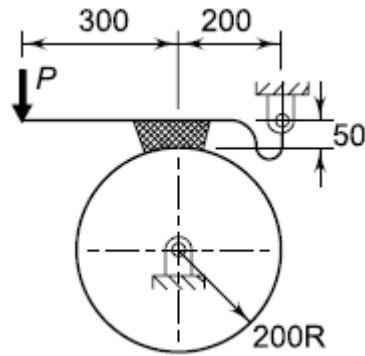

MODULE VI

19. A single disc clutch with both the sides effective is used to run a machine through a shaft rotating at uniform speed of 240 rpm. Coefficient of Friction is 0.25. Inner and outer diameter of the disc are 120mm & 240mm respectively. Maximum intensity of pressure is 120KN/m^2 . Assuming uniform wear theory and moment of inertia of rotating parts of the machine is 7Kg/m^2 . Determine the time to obtain the full speed of the machine and the energy lost in the slipping of the clutches. (6)

OR

20. A cone clutch with asbestos lining transmits 25KW at 600 rpm. Coefficient of Friction is 0.25N/mm^2 . The semi cone angle is 12.5° . The outer diameter of friction lining is 250mm. Considering uniform wear theory and 2 plates engaging, determine (6)
- (i) Inner diameter of friction lining
 - (ii) Face width of the friction lining
 - (iii) Force required to engage the clutch
