

Register No: Name:



**SAINTGITS COLLEGE OF ENGINEERING
KOTTAYAM, KERALA**

(AN AUTONOMOUS COLLEGE AFFILIATED TO
APJ ABDUL KALAM TECHNOLOGICAL UNIVERSITY, THIRUVANANTHAPURAM)

**FIRST SEMESTER M.TECH. DEGREE EXAMINATION(R), MARCH 2021
(MACHINE DESIGN)**

Course Code: 20MEMMDT105

Course Name: ADVANCED MECHANICS OF SOLIDS

Max. Marks: 60

Duration: 3 Hours

(Use of approved data sheets are allowed)

PART A*(Answer all questions. Each question carries 3 marks)*

1. Differentiate between hydrostatic and deviatoric state of stress
2. Write short note on strain energy
3. Explain Saint Venant's principle
4. What are the assumptions used in the solution of the problem of the contact stresses
5. What is warping
6. Define Shear Centre
7. Differentiate between Elastic behavior and Visco-elastic behavior
8. What are the necessary conditions for plastic flow

PART B*(Answer one full question from each module, each question carries 6 marks)***MODULE I**

9. The state of stress at a point with respect to x, y and z axis are given as $\sigma_x = 50$ MPa; $\sigma_y = 30$ MPa; $\sigma_z = 15$ MPa; $\tau_{xy} = 20$ MPa; $\tau_{yz} = 5$ MPa; $\tau_{zx} = 10$ MPa. If a new set of axis x' , y' , z' is formed by rotating x, y, z through 30° about the z axis in the anticlockwise direction, find the new stress tensor: (6)

OR

10. Derive the governing equations of equilibrium in Cartesian coordinate system for a 3D stress analysis problem (6)

MODULE II

11. The displacement field in micro units for a body is given by $U = (x^2+y)i + (3+z)j + (x^2+2y)k$ Determine principal strains at (3,1,-2) and the direction of the minimum principal strain (6)

OR

12. The state of stress at a point(MPa) is given by the following array of terms: Determine the principal stresses and principal directions: (6)

$$\begin{vmatrix} 9 & 6 & 3 \\ 6 & 5 & 2 \\ 3 & 2 & 4 \end{vmatrix}$$

246A1

MODULE III

13. Define Airy's stress function. Discuss how this function can be applied using polynomial method for finding solution to 2D plane stress problems (6)

OR

14. Investigate whether the following polynomial is permissible as an Airy's stress function (6)
 $\phi = A (xy^2 - \frac{3xyh^3}{4})$. If permissible, derive the expressions for stresses.

MODULE IV

15. A steel railway car wheel may be considered as cylinder with a radius of 440 mm. The wheel rolls on a steel rail whose top surface may be considered another cylinder with a radius of 330 mm. For the steel wheel and steel rail, $E = 200$ GPa, $\nu = 0.29$, and $Y = 880$ MPa. If the wheel load is 110 kN, determine σ_{\max} , τ_{\max} , $\tau_{\text{oct max}}$, $2\tau_o$ and the factor of safety against initiation of yielding based on the maximum shear-stress criterion. (6)

OR

16. A cast iron push rod ($E = 117$ GPa and $\nu = 0.20$) in a valve assembly is operated by a steel cam ($E = 200$ GPa and $\nu = 0.29$). The cam is cylindrical in shape and has a radius of curvature of 5 mm at its tip. The surface of the push rod that contacts the cam is spherical in shape with a radius of curvature 4 m so that the rod and cam are in point contact. If the allowable maximum principal stress for cast iron is -1400 MPa, determine the maximum load P that may act on the rod. (6)

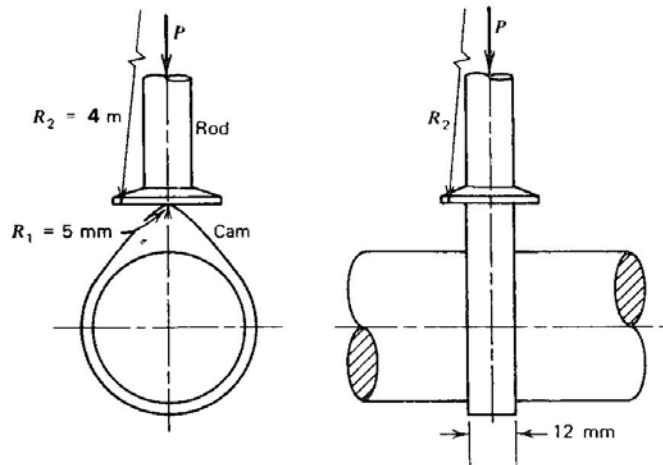

MODULE V

17. A 36 mm x 18 mm rectangular steel shaft is subjected to a torque of 1 kNm. What will be the appropriate position and magnitude of maximum shear stress set up in the shaft. Determine also the corresponding angle of twist per metre length of the shaft. Assume $G = 80$ GN/m² (6)

OR

18. Write short note on Prandtl's membrane analogy (6)

MODULE VI

19. Describe briefly about the elasto-plastic analysis for torsion of bars (6)

OR

20. Explain the four element Maxwell-Kelvin model for visco elasticity (6)
