

Register No.: Name:



SAINTGITS COLLEGE OF ENGINEERING KOTTAYAM, KERALA

(AN AUTONOMOUS COLLEGE AFFILIATED TO
APJ ABDUL KALAM TECHNOLOGICAL UNIVERSITY, THIRUVANANTHAPURAM)

FIRST SEMESTER B.TECH DEGREE EXAMINATION (R), MARCH-APRIL 2021

Course Code: 20EST100

Course Name: ENGINEERING MECHANICS

Max. Marks: 100

Duration: 3 Hours

PART A

(Answer all questions. Each question carries 3 marks)

1. F_1 and F_2 are two collinear forces. When they act in opposite directions, their resultant is 34N, when they act at right angles to each other, their resultant is 50N. Find F_1 and F_2
2. State and explain principle of transmissibility.
3. With the help of sketches, explain how forces involved in the lifting of a load by a wedge are analysed.
4. List out any 4 different types of support used for beams. Explain any two.
5. Discuss the importance of centroid and moment of inertia in the field of engineering.
6. State Pappus-Guldinus theorems. Determine the volume of a body generated by rotation of a rectangular area about a nonintersecting axis using this theorem.
7. A lift has an upward acceleration of 1.5m/s^2 . What force will a man weighing 850N exert on the floor of the lift? What force would he exert if the lift had an acceleration of 1.5m/s^2 downwards?
8. Define stiffness and equivalent stiffness of spring. Give the expression for equivalent stiffness of two springs in series and parallel.
9. What is instantaneous center? How can it be located?
10. Explain work energy principle with an example.

PART B

(Answer one full question from each module, each question carries 14 marks)

MODULE I

11. a) Explain free body diagram with an example. (4)
- b) For the system of forces, determine the magnitude, direction and position of the resultant force about A. (10)

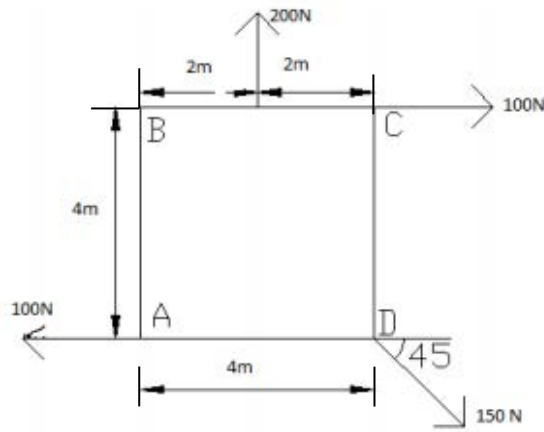

OR

12. a) State and prove Varignon's theorem (6)
- b) A ball of weight 120 N rests in a right-angled groove, as in fig. the sides of the groove are inclined to an angle of 30° and 60° to the horizontal. If all the surfaces are smooth, then determine the reactions R_A and R_C at the points of contact. (8)

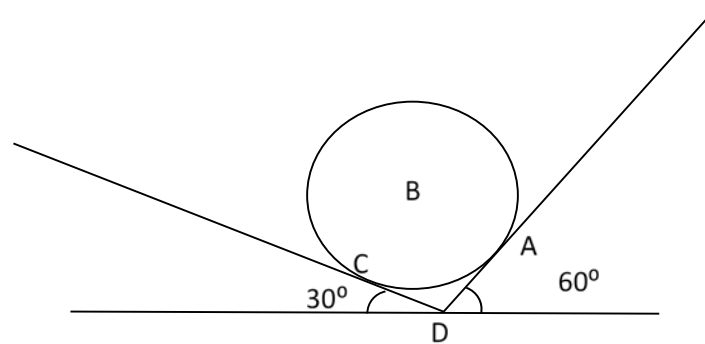

MODULE II

13. a) Define couple and explain its characteristics. With the help of a sketch, explain how a force can be resolved into a force and a couple. (5)
- b) A 4m long ladder, 180N in weight, is supported against a wall (which is perpendicular to the floor) with its foot on the floor. The coefficient of friction between wall and the ladder is 0.2 and that between floor and ladder is 0.4. The ladder supports a weight of 900N at a distance of 1m along the ladder from its top. Compute the least value of the angle between the floor and the ladder for its equilibrium. (9)

OR

14. a) Find the reactions at the supports A (hinged) and B (roller). (6)

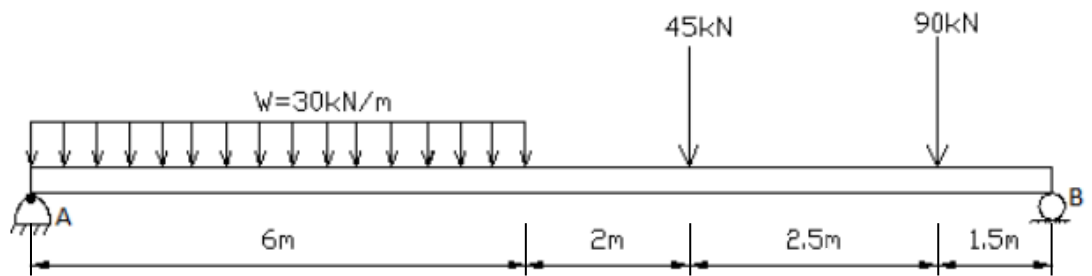

- b) What are the conditions of equilibrium of rigid bodies? (3)
- c) State laws of dry friction. (5)

MODULE III

15. a) A post is held vertical in position by three cable AB, AC, AD as shown in figure. If tension in cable AB is 40N, calculate the required tension in AC and AD, so that the resultant of three forces applied at A is vertical. (14)

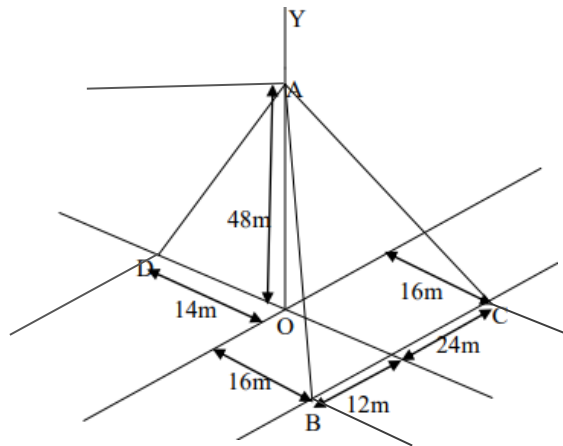

OR

16. a) Determine the centroid of the shaded area. Also find moment of inertia of the shaded area about a horizontal axis passing through the centroid. (10)

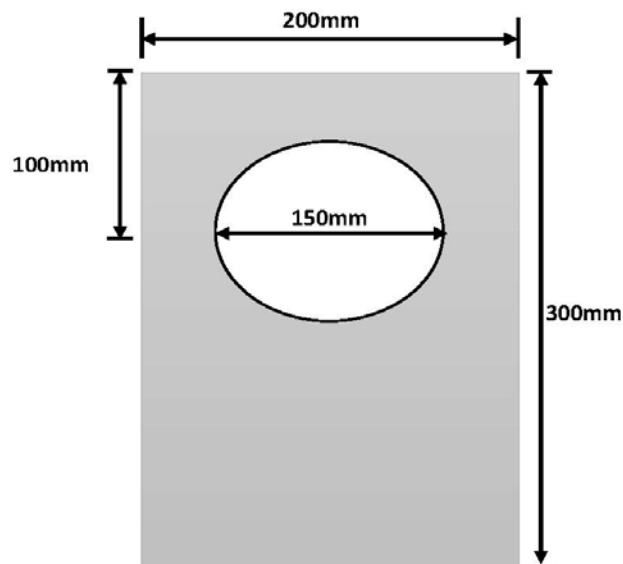

- b) Define radius of gyration and polar moment of inertia. (4)

MODULE IV

17. a) Explain moment of momentum equation for a system of particle. (5)
- b) Two weights 800N and 200N are connected by a thread and they move along a rough horizontal plane under the action of a force of 400N applied to the 800N weight as in fig. (9)
The coefficient of friction between the sliding surface of the weights and the plane is 0.3. Using D'Alembert's principle, determine the acceleration of the weight and tension in the thread.



OR

18. a) State and explain D'Alembert's principle. (4)
- b) A projectile is aimed at a mark on the horizontal plane through the point of projection and falls 12m short when the angle of projection is 15° , while it overshoots the mark by 24m when the same angle is 45° . Find the angle of projection to hit the mark. Assume no air resistance. Take the velocity of projection constant in all cases. (10)

MODULE V

19. a) A cylindrical roller, 50cm in diameter is in contact with two conveyer belts at its top and bottom as shown in Fig. If the belts run at the uniform speed of 5m/s and 3m/s, find angular velocity of the roller when (10)
- (1) The velocities are in the same direction
 - (2) The direction of velocities are opposite

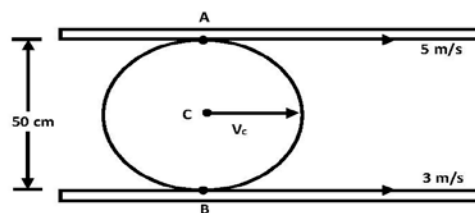

- b) Differentiate between damped and undamped free vibration. (4)

OR

20. a) With neat sketches differentiate between motion of translation and motion of rotation. (6)
- b) A body is moving with simple harmonic motion and has velocities of 8m/s and 3m/s at a distance of 1.5m and 2.5m respectively from the center. Find the amplitude and time period of the body. (8)
