

Register No.: ..... Name: .....

## SAINTGITS COLLEGE OF ENGINEERING (AUTONOMOUS)

(AFFILIATED TO APJ ABDUL KALAM TECHNOLOGICAL UNIVERSITY, THIRUVANANTHAPURAM)

SECOND SEMESTER B.TECH DEGREE EXAMINATION (Supplementary), December 2021

Course Code: 20EST100

Course Name: Engineering Mechanics

Max. Marks: 100

Duration: 3 Hours

### PART A

(Answer all questions. Each question carries 3 marks)

- |   | CO  |
|---|-----|
| 1. State the Principle of Transmissibility with a neat sketch.  | [1] |
| 2. State the Parallelogram law of forces with a neat sketch.  | [1] |
| 3. Define sliding of friction and explain briefly with a sketch.  | [2] |
| 4. A simply supported beam AB of span 6m carries point loads of 3kN and 6kN at a distance of 2m and 4m from the left end A. Find the reactions at A and B.  | [2] |
| 5. With a neat sketch, describe how to arrive at the surface area of a cone with the help of Pappus Guldinus theorem.   | [1] |
| 6. Define the radius of gyration.   | [2] |
| 7. From basics, derive an equation for the maximum height attained by a projectile whose angle of projection is ' $\alpha$ ' with respect to horizontal and velocity of projection is ' $u$ 'm/s. | [3] |
| 8. An elevator has an upward acceleration of $1\text{m/s}^2$ . What pressure will be transmitted to the floor of the elevator by a man weighing 600N traveling in the elevator?                   | [4] |
| 9. A wheel rotating about a fixed axis at 20rpm is uniformly accelerated for 70s during which it makes 50 revolutions. Find the angular velocity at the end of this interval.                     | [4] |
| 10. Define frequency, time period, and amplitude of a simple harmonic motion.   | [4] |

### PART B

(Answer one full question from each module, each question carries 14 marks)

#### MODULE I

- |   | CO  | Marks |
|---|-----|-------|
| 11. Three cylinders are piled in a rectangular box whose bottom width is 360mm as shown in the figure. Neglecting friction, determine the reaction between cylinder A and the vertical wall. The radius of cylinder C is 100mm, and the weight is 40N. The radius of cylinder B is 120mm, and the weight is 80N. The radius of cylinder A is 80mm, and the weight is 30N. | [1] | (14)  |

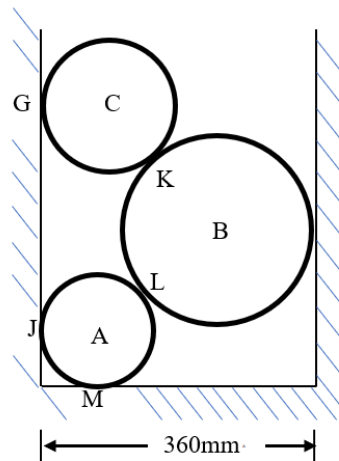

OR

12. The figure shows a particular position of the connecting rod BA and crank AO. At this position of angle AOB  $45^\circ$ , the connecting rod exerts a force 2500N on the crank pin at A. Resolve this force into horizontal and vertical components at A. Also, resolve the given force at A along AO and along a direction perpendicular to AO.

CO Marks

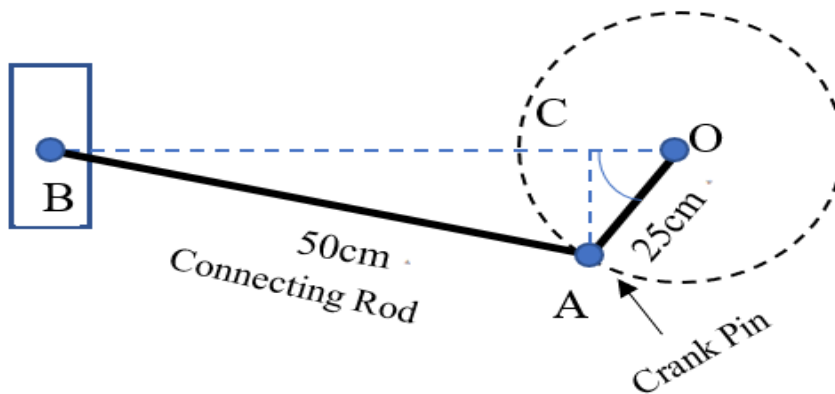

[2] (14)

MODULE II

13. Two blocks A and B of weights 500N and 1000N are placed on an inclined plane. The blocks are connected by a string parallel to the inclined plane. Coefficient of friction between the inclined plane and block A is 0.15 and that for block B is 0.4. Find the inclination of the plane when the motion is about to take place. Also, calculate the tension in the string. Block A is below block B as shown in the figure.

CO Marks

[2] (14)

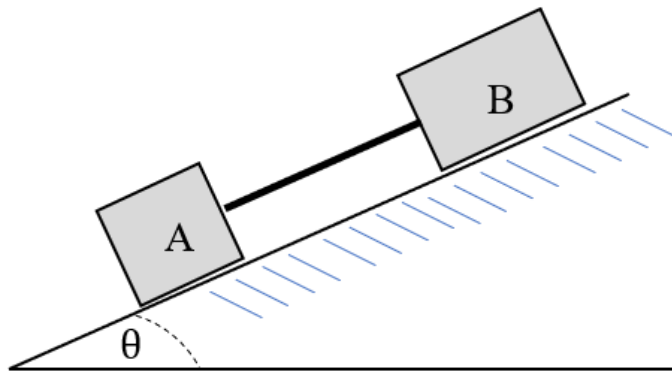

OR

14. A uniform ladder 3m long weighs 200N. It is placed against a vertical wall with which it makes an angle of 30 degrees. The coefficient of friction between the wall and the ladder is 0.25 and that between the floor and the ladder is 0.35. The ladder in addition to its own weight has to support a load of 1000N at its top end. Find the (a) Horizontal force P to be applied to the ladder at floor level to prevent slipping. (b) If the force P is not applied, what should be the minimum inclination of the ladder with the horizontal so that there is no slipping of it with load at its top end.

CO

Marks

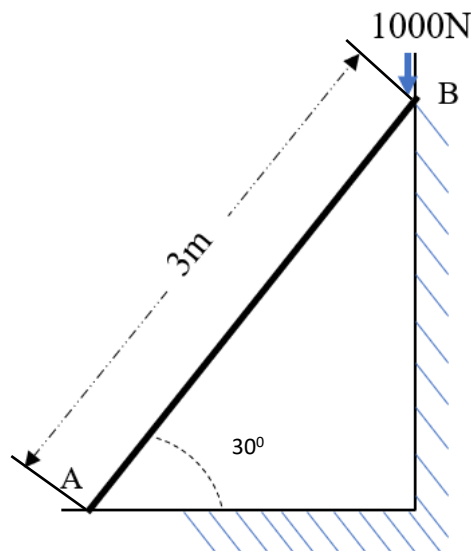

[2]

(14)

## MODULE III

15. The cross-section of a culvert is shown in the figure. Compute the moment of inertia about the horizontal AA axis.

CO

Marks

[3]

(14)

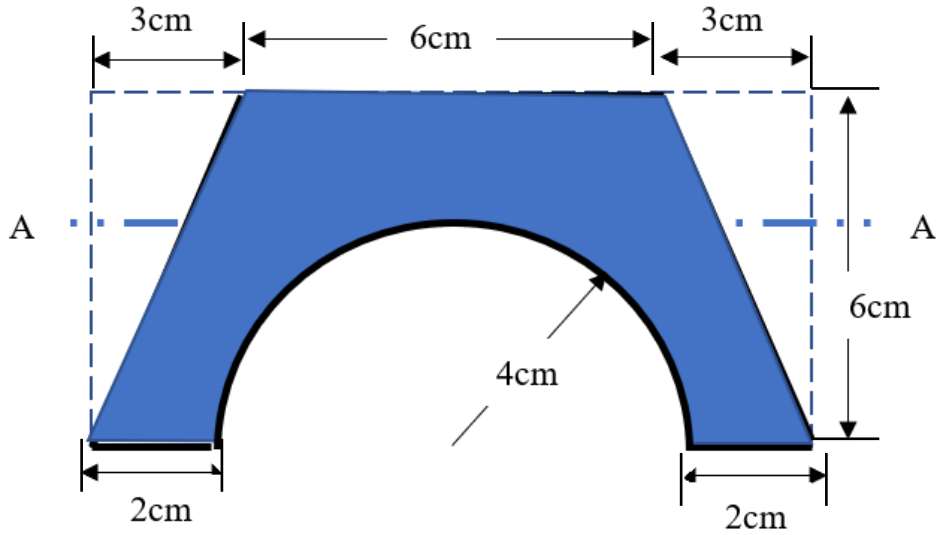

OR

16. A tripod supports a load of 2kN as shown in the figure. The ends A B and C are in the XZ plane. Find the forces in the three legs of the tripod.

CO Marks

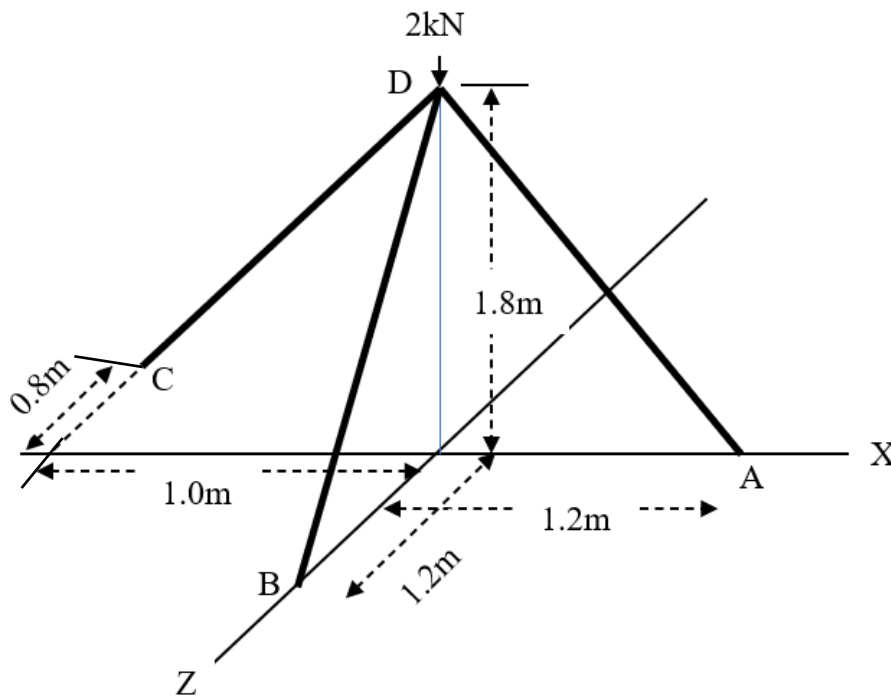

[4] (14)

MODULE IV

17. A train of weight 1500kN is ascending (moving up) a slope of 1 in 100 with a uniform speed of 36km/hr. Find the power exerted by the engine if road resistance is 5N per kN weight of the train.

CO Marks

[4] (14)

OR

18. Two blocks A and B are held stationary 10m apart on a 20degree incline as shown. The coefficient of friction between the plane and block A is 0.3 while it is 0.2 between the plane and block B. If the blocks are released simultaneously,

CO Marks

[4] (14)

calculate the time taken and the distance traveled by each block before they are on the verge of collision.

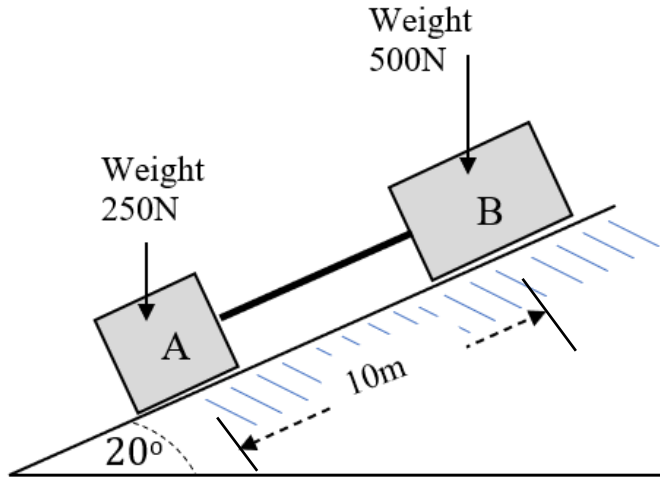

MODULE V

- |   | CO  | Marks |
|---|-----|-------|
| 19. For a mass-spring system under undamped free vibration, derive the expression for natural frequency in terms of spring constant 'k' and mass 'm' with the help of a neat sketch. Also, find a weight that has to be attached to a spring of spring constant 1.5N/cm to have periodic time of 1.5s to oscillate. | [5] | (14)  |

OR

- |  | CO  | Marks |
|--|-----|-------|
| 20. A wheel rotating about a fixed axis at 24rpm is uniformly accelerated for 70seconds, during which it makes 50revolutions. Find (i) angular velocity at the end of this interval (ii) the time required for the speed to reach150rpm. | [3] | (14)  |

\*\*\*\*\*