

Reg No:

Name:.....

APJ ABDUL KALAM TECHNOLOGICAL UNIVERSITY
SEVENTH SEMESTER B.TECH DEGREE (HONS.) EXAMINATION, DEC 19

Course code: 01EE6407

Course Name: POWER QUALITY

Answer *any two full* questions from *each* part

Limit answers to the required points.

Max. Marks: 60

Duration: 3 hours

PART A

- 1 a. Explain the major power quality issues in distribution systems. (5)
b. What are the objectives of power quality monitoring and the functions of power quality monitoring instruments (4)
- 2 a. Mention different types of power quality disturbances and explain how its affect the power system (4)
b. Explain the mechanism of harmonics generation and define the following indices
1)THD 2)TIF 3)DIN (5)
- 3 a. Mention the various IEEE standards for power quality (2)

b. A three-phase balanced supply system has phase voltages $V_a = 1.0 \angle 0^\circ$ pu, $V_b = 1.0 \angle 240^\circ$ pu, and $V_c = 1.0 \angle 120^\circ$ pu and unbalanced load currents $I_a = 0.75 \angle -20^\circ$ pu, $I_b = 0.65 \angle 270^\circ$ pu, and $I_c = 0.35 \angle 90^\circ$ pu. Find (a) the total complex power, (b) the positive-sequence component of power, (c) the negative-sequence component of power, and (d) the zero-sequence component of power. (7)

PART B

- 4 a. Explain the effect of harmonics on different power system equipment. (4)
b. Discuss the modeling of Shunt capacitor banks for harmonic studies (5)
- 5 a. Explain the difference between Fourier Transform, Fourier Series and Discrete Fourier Transform (6)
b. Discuss the different windowing function used in Fourier Transform (3)
- 6 a. Mention the different types of loads that cause power quality problems (3)

b For a quasi-square wave (120° pulse width) of current with an amplitude I of 100A shown in Figure, calculate (a) crest factor (CF), (b) distortion factor (DF), and (c) total harmonic distortion (THD). (6)

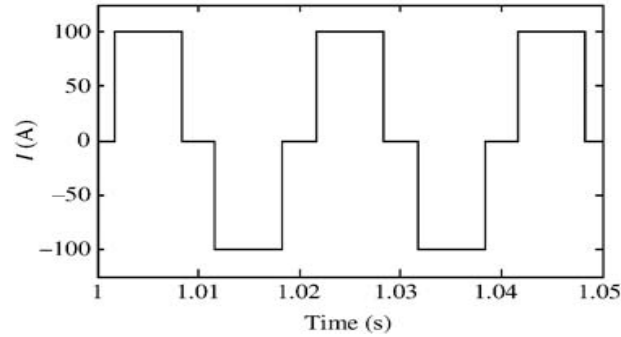

PART C

- 7 a. Discuss shunt and series active filtering scheme with relevant diagrams. (6)
 b. Mention in detail about the power quality management in smart grid. (6)
- 8 a. Explain the working of Dynamic Voltage restorer with the help of a diagram. (6)
 b. A single-phase shunt active power filter shown in figure is employed for harmonic current compensation for a single-phase 230 V, 50 Hz, fed diode bridge converter drawing 20 A constant DC current. Calculate current, voltage, and the VA rating of the APF to provide harmonic compensation at unity power factor. Let the supply be stiff enough so that the distortion in voltage at the point of common coupling is negligible.. (6)

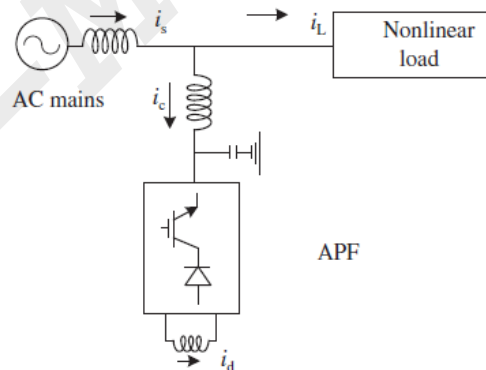

- 9 a. Discuss the EMI issues and how to shield it . (6)
 b. Explain the terms 1.) Common mode noise 2.) Transverse mode noise 3.) Conducted emission 4.) Radiated emission (6)