

Reg No.: \_\_\_\_\_

Name: \_\_\_\_\_

**APJ ABDUL KALAM TECHNOLOGICAL UNIVERSITY**  
SEVENTH SEMESTER B.TECH DEGREE EXAMINATION(S), MAY 2019

**Course Code: AE407**

**Course Name: -DIGITAL CONTROL SYSTEM**

Max. Marks: 100

Duration: 3 Hours

**PART A**

*Answer any two full questions, each carries 15 marks.*

- |   |   | Marks |
|---|---|-------|
| 1 | a) What are the merits and demerits of digital control system?  | (3)   |
|   | b) With suitable timing diagram explain the following characteristics of a sample and hold device.<br>(i) Acquisition time (ii) Aperture time (iii) Settling time | (7)   |
|   | c) Obtain the expression for the transfer function of a polygonal hold system.  | (5)   |
| 2 | With suitable diagrams explain how data reconstruction is done in zero order hold and first order hold. Derive transfer functions for each.                       | (15)  |
| 3 | a) Find the inverse z transform of $X(z) = \frac{2z^3 + z}{(z-2)^2(z-1)}$   | (6)   |
|   | b) Describe the mapping of the following locus from s-plane to z-plane  | (9)   |
|   | i. Constant damping loci  |       |
|   | ii. Constant frequency loci   |       |
|   | iii. Constant damping ratio loci  |       |

**PART B**

*Answer any two full questions, each carries 15 marks.*

- 4 a) Obtain the Pulse transfer function of the given closed loop system. (10)

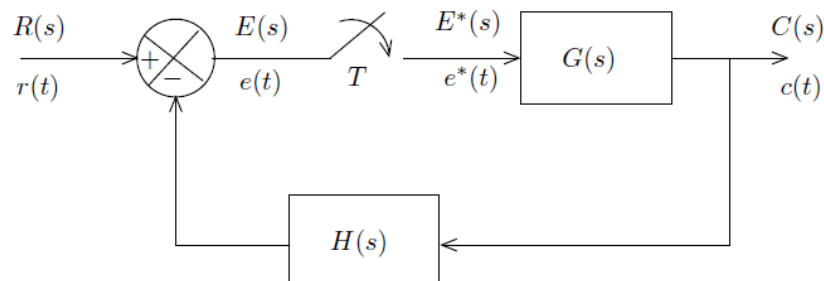

- b) Derive the expression for pulse transfer function of an LTI system with sampled data input (5)
- 5 Determine the pulse transfer function of the closed loop system given below for a (15)

sampling time of 1s and open loop gain  $K=1$ .

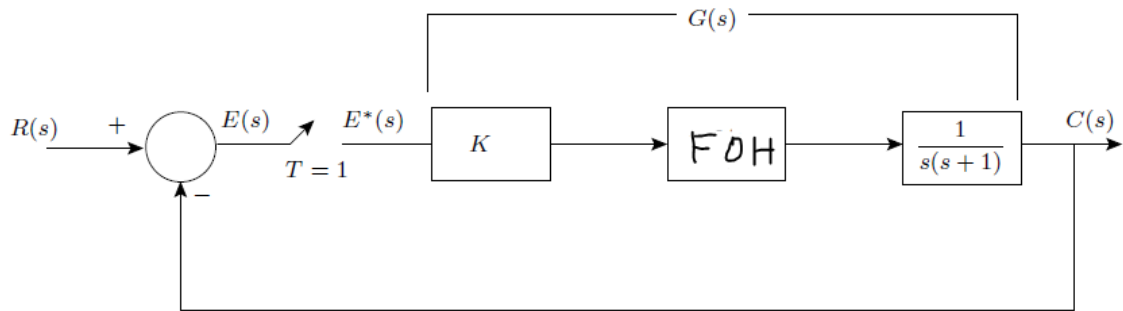

- 6 a) What do you mean by gain margin and phase margin? Explain (5)  
 b) Derive the expression for acceleration error constant and velocity error constant of a Type 1 digital system (10)

### PART C

*Answer any two full questions, each carries 20 marks.*

- 7 a) Using nested programming method, obtain the state equation and output equation for the following system (10)  

$$\frac{Y(z)}{U(z)} = \frac{z^{-1} + 5z^{-2}}{1 + 4z^{-1} + 3z^{-2}}$$
- b) Write the state space representation of a linear time invariant discrete time control system. Explain various matrices in the representation. Prove that this representation is not unique. (10)
- 8 a) Explain in detail the procedure for state regulator design using pole placement method for a digital control system (10)  
 b) Derive the expression for state transition matrix using z-transform method (10)
- 9 a) Determine whether the following systems are completely state controllable (8)  
 i. 
$$\begin{bmatrix} x_1(k+1) \\ x_2(k+1) \end{bmatrix} = \begin{bmatrix} -1 & 0 \\ 0 & -2 \end{bmatrix} \begin{bmatrix} x_1(k) \\ x_2(k) \end{bmatrix} + \begin{bmatrix} 2 \\ 3 \end{bmatrix} u(k)$$
  
 ii. 
$$\begin{bmatrix} x_1(k+1) \\ x_2(k+1) \end{bmatrix} = \begin{bmatrix} -1 & 0 \\ 0 & -2 \end{bmatrix} \begin{bmatrix} x_1(k) \\ x_2(k) \end{bmatrix} + \begin{bmatrix} 2 \\ 0 \end{bmatrix} u(k)$$
- b) Explain the effects of finite word length and quantization on controllability and closed-loop placement. (12)

\*\*\*\*