

Reg No.: \_\_\_\_\_

Name: \_\_\_\_\_

**APJ ABDUL KALAM TECHNOLOGICAL UNIVERSITY**  
FIRST SEMESTER B.TECH DEGREE EXAMINATION, DECEMBER 2018

**Course Code: BE 100**  
**Course Name: ENGINEERING MECHANICS**

Max. Marks: 100

Duration: 3 Hours

**PART A**

*Answer all questions.*

- 1 State and prove Varignon's theorem of moments. (5)
- 2 A force acts at the origin in a direction defined by the angles  $\Theta_y = 65^\circ$  and  $\Theta_z = 40^\circ$ . The X component of the force is -90kN. Determine the other components of force and value  $\Theta_x$ . Also find the magnitude of force. (5)
- 3 A body weighing 150N is at rest on a horizontal plane. If a horizontal force of 108N will just cause it to slide, determine the limiting friction and coefficient of friction. (5)
- 4 Define a) Radius of gyration b) Product of inertia c) Polar moment of inertia. (5)
- 5 Explain the concept of instantaneous centre with figure. (5)
- 6 Differentiate between free vibration and forced vibration of bodies. (5)
- 7 State D'Alembert's principle. Write the equations of dynamic equilibrium for the motion of a lift moving upwards with an acceleration 'a' m/s<sup>2</sup> carrying a weight of 'W' N. (5)
- 8 Determine the weight, which is to be connected to a spring of stiffness 5N/cm, so that the weight is oscillating with a time period of 1sec. (5)

**PART B**

**SET I**

*Answer any 2 questions.*

- 9 a) Distinguish between a force and a couple. What are the characteristics of a couple? (5)
- b) Determine the support reactions at 'A' and 'B'. (5)

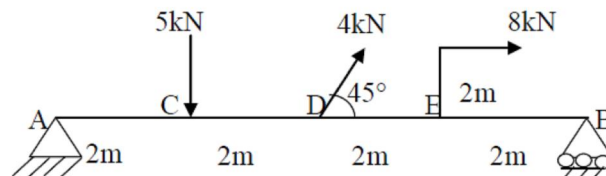

- 10 A force P is directed from a point A (4,1,4) and a point B (-3,4,-1). If it causes a moment  $M_z = 1900\text{Nm}$ , determine the magnitude of force P and the moment of (10)

this force about X and Y axes.

- 11 Find the magnitude, direction and position of the resultant. (10)

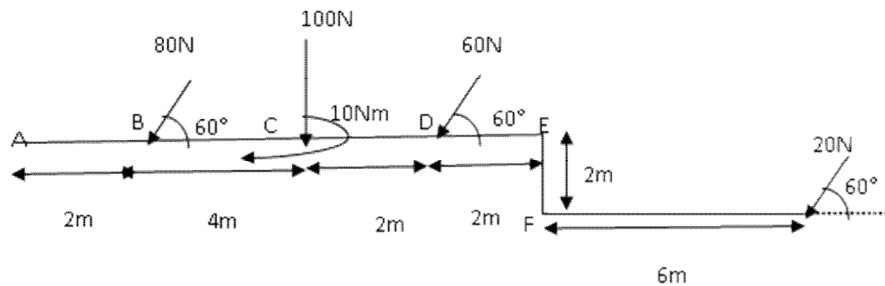

**SET II**

*Answer any 2 questions.*

- 12 Determine the vertical force P required to drive the wedge B downwards in the arrangement shown. The angle of friction is  $12^\circ$  at all rubbing faces. Angle of wedge is  $20^\circ$ . (10)

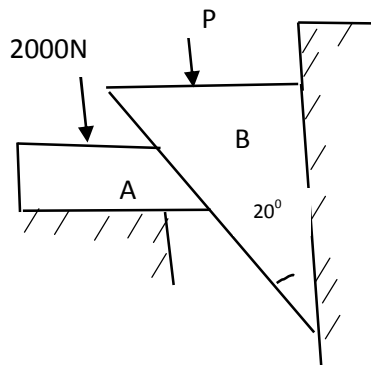

- 13 Find the centroid of the cross section of a culvert as shown in figure below. Determine the M. I of horizontal axis XX passing through top of the semi-circle. (10)

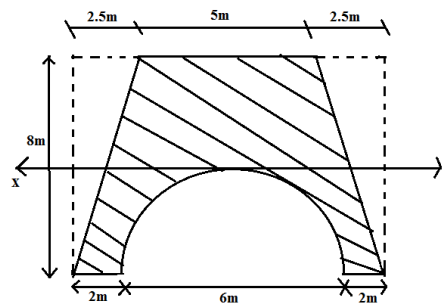

- 14 a) A body weighing 1000N rests on an inclined plane and is subjected to a horizontal force so as to keep it in equilibrium. If the angle of the plane is  $30^\circ$  and the angle of limiting friction is  $10^\circ$ , find the least and greatest value of the force to keep the body in equilibrium. (6)

- b) For 24mm length and 12mm breadth rectangle, find moment of inertia about an axis inclined at  $30^\circ$  to OX axis. (4)

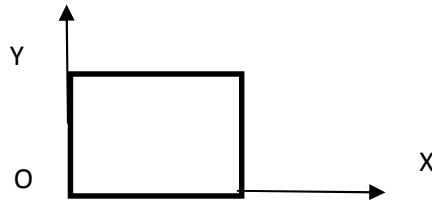

**SET III**

*Answer any 2 questions.*

- 15 A body of mass 4.5 kg is placed on a smooth table at a distance of 2 m from the edge. The body is connected by a light string passing over a smooth pulley. The other end of the string is connected with a body of mass 2.5 kg. Find i) acceleration of the system and ii) time that elapses before the body reaches the edge of the table. (10)
- 16 a) A particle is moving with simple harmonic motion and performs 8 complete oscillations per minute. If the particle is 5 cm from the centre of the oscillation, determine the amplitude, the velocity of the particle and maximum acceleration. Given that the velocity of the particle at a distance of 7 m from the centre of oscillation is 0.6 times the maximum velocity. (8)
- b) Explain the term 'stiffness of a spring'. (2)
- 17 a) The length of connecting rod and crank in a reciprocating pump are 50 cm and 12 cm respectively. The crank is rotating at 300 rpm. Find the velocity with which the piston will move, when the crank has turned through an angle of  $30^\circ$  from the inner dead centre. (5)
- b) Two springs of stiffness 4 kN/m and 6 kN/m are connected in series. Upper end of the compound spring is connected to a ceiling and lower end carries a block of mass 50 kg. The block is pulled 40 mm down from its position of equilibrium and then released. Determine the period of vibration, maximum velocity and acceleration of the block. (5)

\*\*\*\*