

Reg No.: _____

Name: _____

APJ ABDUL KALAM TECHNOLOGICAL UNIVERSITY
FIRST SEMESTER B.TECH DEGREE EXAMINATION, DECEMBER 2018

Course Code: BE110

Course Name: ENGINEERING GRAPHICS

Max. Marks: 50

Duration: 3 Hours

PART A

Answer any two questions, each carries 10 marks.

- | | | Marks |
|---|---|-------|
| 1 | A line AB has its point A in HP and 30 mm in front of VP. Point B in VP and 60mm above HP. The distance between end projectors are 70 mm. Draw the projections and find true length of line and inclinations with HP and VP. | (10) |
| 2 | The point A of a line is 40 mm above HP and 20 mm in front of VP. The point B is 30 mm below HP and 50 mm behind VP. The distance between end projectors is 100 mm. Find the true length of the line and its inclination with HP and VP. | (10) |
| 3 | A pentagonal prism of base edge 30 mm and height 70 mm is resting on HP on its base edge such that the rectangular face containing that edge is inclined 45° to HP and the base edge on which it is resting is inclined 30° to VP | (10) |

PART B

Answer any three questions, each carries 10 marks.

- | | | |
|---|---|------|
| 4 | Draw the isometric view of a right regular hexagonal prism of side of base 30mm and height 70mm resting on its base on HP, having a through circular hole of diameter 30mm drilled centrally through it along the axis. | (10) |
| 5 | Figure shows the isometric view of a machine component with all the dimensions in mm. Draw its front view, top view and any one side view. Arrow (X) indicates the direction to obtain the view from the front. | (10) |

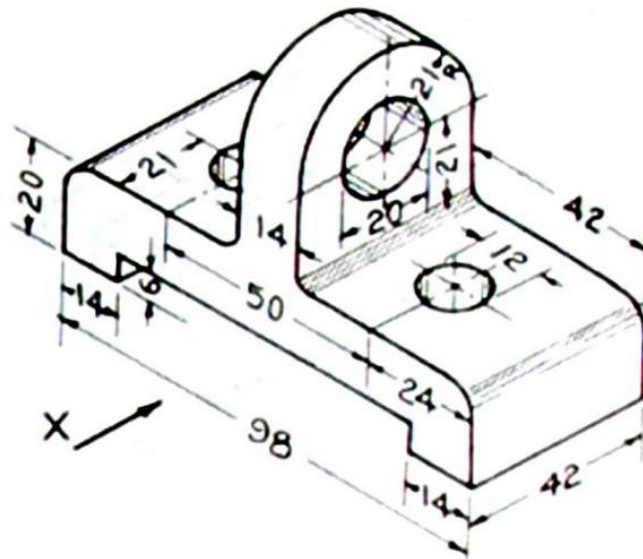

- | | | |
|---|---|------|
| 6 | A cone of base diameter 60 mm and axis length 70 mm is resting on HP on its base. It is cut by a section plane which is perpendicular to VP and parallel to the right most generator in the front view, and section plane is 10 mm away from this generator. Draw the front view, sectional top view and true shape of the section. | (10) |
|---|---|------|

- 7 A pentagonal prism, having a base with a 30 mm side and a 70 mm long axis, is resting on its base on H.P. such that one of the rectangular faces is parallel to the V.P. it is cut by an auxiliary inclined plane making an angle 45° with the H.P. and passes through the midpoint of the axis. Draw the development of the lateral surface of the truncated prism. (10)
- 8 A square prism of base side 35mm and axis length 65mm is resting on one of its rectangular faces on GP. The base nearer to PP is parallel to it and 15mm behind it. The station point is 50mm to the left of the axis of the prism, 55mm above the ground plane and 30mm in front of the picture plane. Draw the perspective view of the prism. (10)
