

R1904

Final Scheme/ Answer Key for Valuation

Scheme of evaluation (marks in brackets) and answers of problems/key

APJ ABDUL KALAM TECHNOLOGICAL UNIVERSITY

FIRST SEMESTER B.TECH DEGREE EXAMINATION, DECEMBER 2018

Course Code: BE110

Course Name: ENGINEERING GRAPHICS

General instructions:

- 1) **Award the marks of dimensioning (1 mark in each question) only if the solution is complete, correct and neat with dimensions**

Max. Marks: 50

Duration: 3 Hours

PART A

Answer any two questions, each carries 10 marks.

Marks

- 1 A line AB has its point A in HP and 30 mm in front of VP. Point B in VP and 60mm above HP. The distance between end projectors are 70 mm. Draw the projections and find true length of line and inclinations with HP and VP.
Fixing front and top views – 4 marks, finding true length – 3marks, inclinations with HP and VP – 2 mark, Dimensioning – 1 mark (10)
(NB: The students can use line rotation OR plane rotation method for getting the solution . Carefully analyse the answer and allot marks)
- 2 The point A of a line is 40 mm above HP and 20 mm in front of VP. The point B is 30 mm below HP and 50 mm behind VP. The distance between end projectors is 100 mm. Find the true length of the line and its inclination with HP and VP.
Fixing front and top views – 4 marks, finding true length – 3marks, inclinations with HP and VP – 2 mark, Dimensioning – 1 mark (10)
(NB: The students can use line rotation OR plane rotation method for getting the solution. Carefully analyse the answer and allot marks)
- 3 A pentagonal prism of base edge 30 mm and height 70 mm is resting on HP on its base edge such that the rectangular face containing that edge is inclined 45° to HP and the base edge on which it is resting is inclined 30° to VP
Simple position – 3 marks, First position – 3 marks, Final position – 3 marks Dimensioning – 1 mark (10)

PART B

Answer any three questions, each carries 10 marks.

- 4 Draw the isometric view of a right regular hexagonal prism of side of base 30mm and height 70mm resting on its base on HP has a circular hole of diameter 30mm drilled centrally through it along the axis.
Orthographic views– 3 marks, Isometric of hexagonal prism – 3 marks Isometric of internal hole – 3 marks Dimensioning – 1 mark (10)
NB: 1) Students can fix the base edge condition in any way, since the base edge condition is not mentioned in question.
2) Complete orthographic view is not necessary for drawing the isometric view. In such case, if isometric view is complete and correct, award full mark

- 5 Figure shows the isometric view of a machine component with all the dimensions in mm. Draw its front view, top view and any one side view. Arrow (X) indicates the direction to obtain the view from the front. (10)

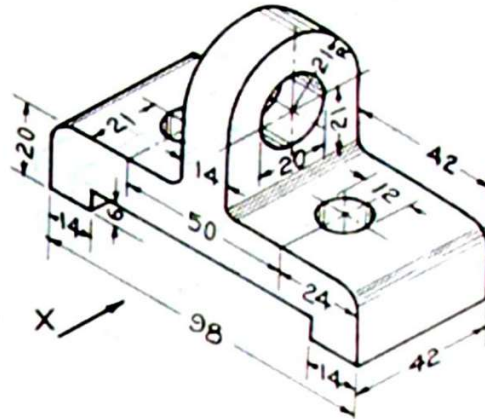

- front view– 2 marks, top view– 3 marks and any one side view– 2marks ,Dimensioning – 1 mark, following first angle drawing- 2marks**
- 6 A cone of base diameter 60 mm and axis length 70 mm is resting on HP on its base. It is cut by a section plane which is perpendicular to VP and parallel to the right most generator in the front view, and section plane is 10 mm away from this generator. Draw the front view, sectional top view and true shape of the section. (10)
Simple position– 3 marks, section line – 2 marks, sectional top view – 2 marks, True shape – 2 marks, Dimensioning – 1 mark
- 7 A pentagonal prism, having a base with a 30 mm side and a 70 mm long axis, is resting on its base on H.P. such that one of the rectangular faces is parallel to the V.P. it is cut by an auxiliary inclined plane making an angle 45° with the H.P. and passes through the midpoint of the axis. Draw the development of the lateral surface of the truncated prism. (10)
Orthographic views– 3 marks, Development of full Prism – 3 marks, Development of truncated Prism – 3 marks, Dimensioning – 1 mark
(NB: The shape of development is depended on the edge from which the development is started. Carefully analyse the answer and allot marks)
- 8 A square prism of base side 35mm and axis length 65mm is resting on one of its rectangular faces on GP. The base nearer to PP is parallel to it and 15mm behind it. The station point is 50mm to the left of the axis of the prism, 55mm above the ground plane and 30mm in front of the picture plane. Draw the perspective view of the prism. (10)
Orthographic views– 3 marks, locating station point – 2 marks, Perspective view – 4 marks, Dimensioning – 1 mark
(NB : The students can use visual ray method using any quadrant OR vanishing point method.Carefully analyse the answer and allot marks)
