

Reg No.: _____

Name: _____

APJ ABDUL KALAM TECHNOLOGICAL UNIVERSITY
FIFTH SEMESTER B.TECH DEGREE EXAMINATION, DECEMBER 2018

Course Code: ME301

Course Name: MECHANICS OF MACHINERY

Max. Marks: 100

Duration: 3 Hours

PART A

Answer any three full questions, each carries 10 marks.

Marks

- | | | |
|---|---|------|
| 1 | What is meant by inversion? Explain with neat figures, the different inversions of four bar mechanism. | (10) |
| 2 | Explain with neat sketch the Geneva mechanism. | (10) |
| 3 | Find out the acceleration of the slider D and the angular acceleration of link CD for the engine mechanism shown in the Figure. The crank OA rotates uniformly at 180 rpm in clockwise direction. The various lengths are: OA=150 mm; AB=450 mm; PB=240 mm; BC=210 mm; CD=660 mm. | (10) |

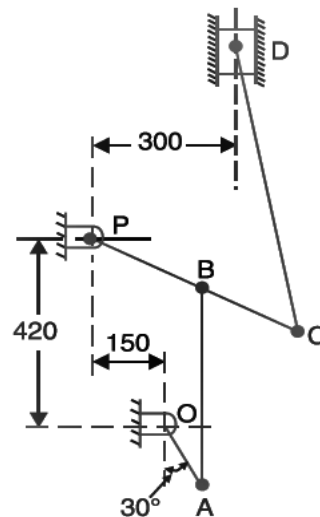

- | | | |
|---|--|------|
| 4 | Derive the relation for displacement, velocity and acceleration of a cam follower with cycloidal motion. | (10) |
|---|--|------|

PART B

Answer any three full questions, each carries 10 marks.

- | | | |
|---|---|------|
| 5 | Draw the cam profile for the following conditions: Follower type = roller follower, offset to the right by 5 mm; lift = 30 mm; base circle radius = 25 mm; roller radius = 5mm; out stroke with SHM, for 120° cam rotation: dwell for 60° cam rotation; return stroke during 120° cam rotation; first half return stroke with uniform velocity and second half with parabolic motion; dwell for the remaining period. | (10) |
| 6 | What is a tangent cam? Find the expressions for the velocity and acceleration of a roller follower for such a cam. | (10) |

- 7 (a) What are the advantages and disadvantages of involute gears over cycloidal gears? (6)
- (b) List the advantages of helical gears over spur gears? (4)
- 8 Two gear wheels mesh externally and are to give a velocity ratio of 3 to 1. The teeth are of involute form, module is 6 mm, addendum is one module, and pressure angle is 20° . The pinion rotates at 90 rpm. Determine (i) The number of teeth on the pinion to avoid interference and the corresponding number of teeth on the wheel (ii) The length of path of contact and arc of contact (iii) The number of pairs of teeth in contact, and (iv) The maximum velocity of sliding. (10)

PART C

Answer any four full questions, each carries 10 marks.

- 9 What is a gear train? Explain with neat sketches the different types of gear trains. (10)
- 10 An internal wheel B with 80 teeth is keyed to a shaft F. A fixed internal wheel C with 82 teeth is concentric with B. A compound wheel D-E gears with the two internal wheels; D has 28 teeth and gears with C while E gears with B. The compound wheels revolve freely on a pin which projects from a disc keyed to a shaft A, co-axial with F. If the wheels have the same pitch and the shaft A makes 800 r.p.m., what is the speed of the shaft F? (10)

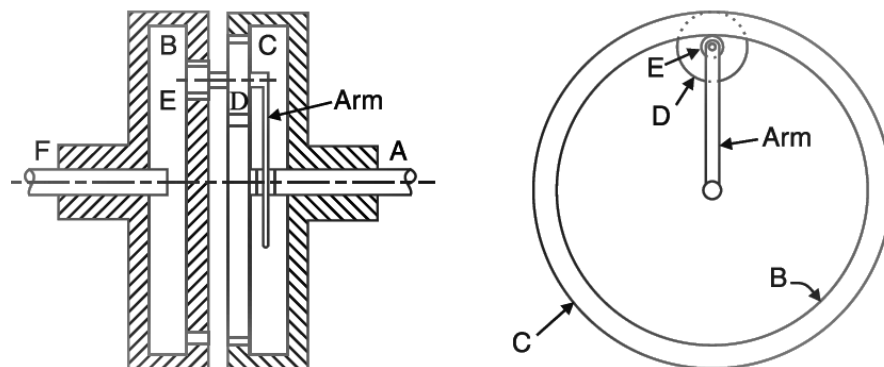

- 11 a) Explain the different tasks involved in the kinematic synthesis of mechanisms. (6)
- b) Explain Chebyshev's precision points. (4)
- 12 a) Explain the different types of kinematic synthesis with examples. (6)
- b) Explain the overlay method of synthesis. (4)
- 13 Derive a relation for Freudenstein's equation for the synthesis of mechanisms. (10)
- 14 Synthesize a four bar mechanism by using three precision points to generate $y = x^{1.5}$, where 'x' varies between 1 and 4. Assume $\theta_s = 30^\circ$; $\Delta\theta_s = 90^\circ$; $\phi_s = 90^\circ$; $\Delta\phi = 90^\circ$. Take the length of the fixed link as 25 mm. (10)
